

NOTE: LUMINAIRE 84 029 – SEE SPECIFICATIONS

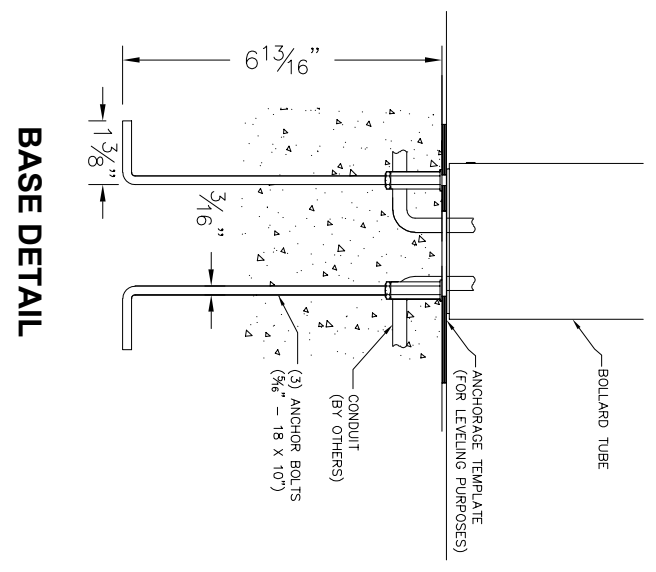
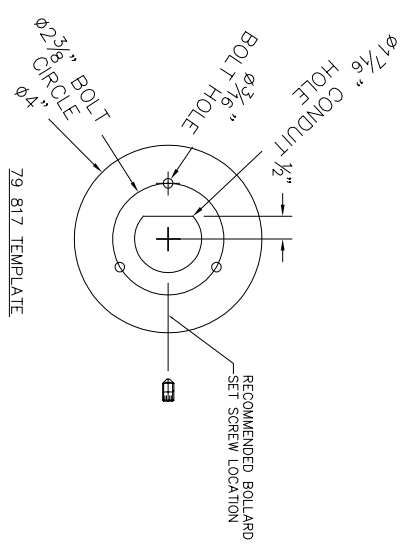

BASE DETAIL

TYPE: _____

SUBMITTAL APPROVAL			CAT NO.: LUMINARE 84029	BEGA 1000 Bega Way Carpinteria, Ca. 93013 (805) 684-0533
			APPROVED BY: _____	
SIGNED: _____	DATE: _____	LOCATION: -		
REV.	DATE	DESCRIPTION	DRAWN: SB DATE: 10/11/2018 FILE NAME: 84029.DXF	

This print contains confidential information which is the property of BEGA U.S. By acceptance this information, the borrower agrees that it will not be used for any other purpose other than that which it was loaned.