

NOTE: LUMINAIRE 84 024 – SEE SPECIFICATIONS

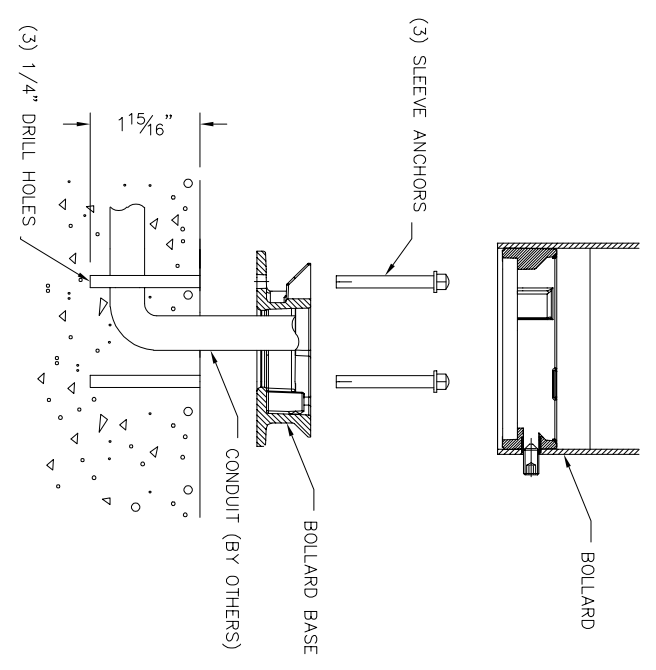
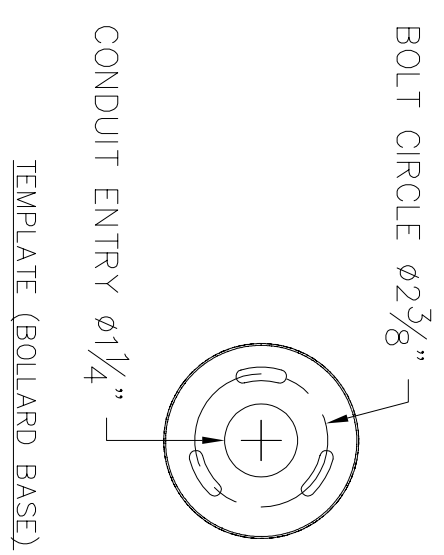

BASE DETAIL

TYPE:

SUBMITTAL APPROVAL

APPROVED BY: _____
 SIGNED: _____ DATE: _____

CAT NO.:	LUMINAIRE 84024
PROJECT:	-
LOCATION:	-
DRAWN:	SB
DATE:	10/11/2018
FILE NAME:	84024.DXF

1000 Bega Way
 Carpinteria, Ca. 93013
 (805) 684-0533

REV.	DATE	DESCRIPTION

This print contains confidential information which is the property of BEGA U.S. By acceptance this information, the borrower agrees that it will not be used for any other purpose other than that which is was loaned.