

BOTTOM VIEW

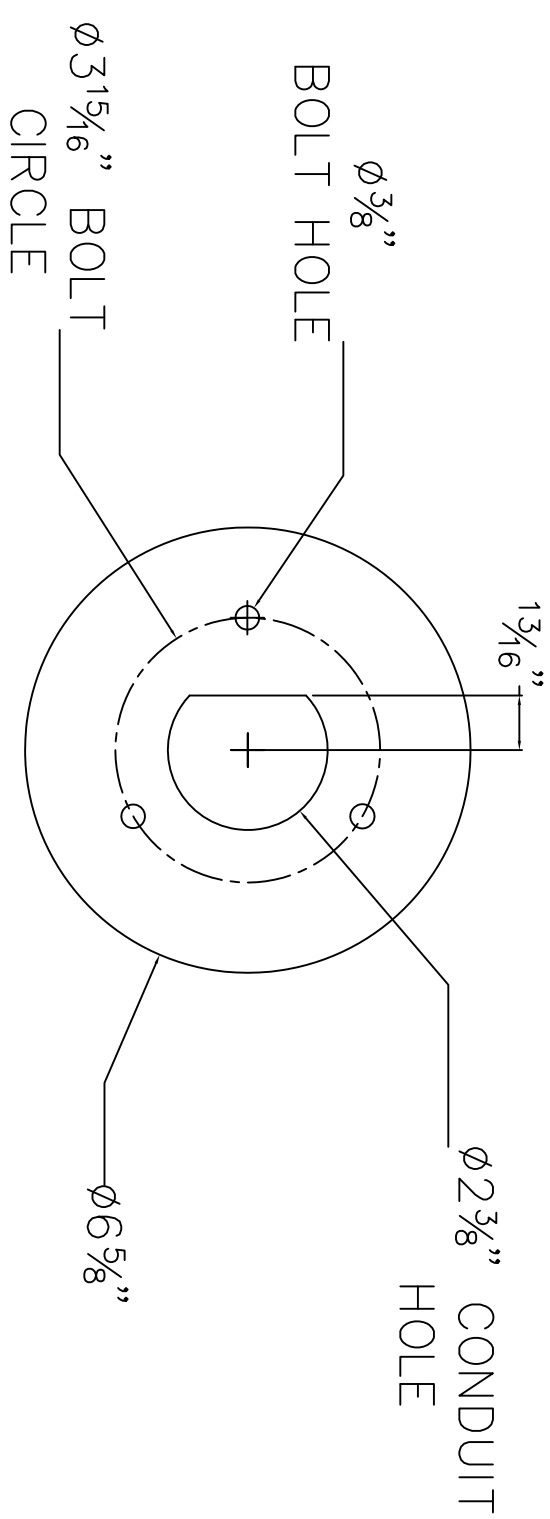

Z9 817 TEMPLATE (SCALE 1:2)

NOTES:
 1. LUMINAIRE # 77 321 – SEE SPECIFICATIONS

TYPE: _____

SUBMITTAL APPROVAL
 APPROVED BY: _____
 SIGNED: _____ DATE: _____

CAT NO.: 77 321
 PROJECT: -
 LOCATION: -
 DRAWN: AV DATE: 8/6/15 File Name: 77321.dxf

BEGA
 1000 Bega Way
 Carpinteria, Ca. 93013
 (805) 684-0533

REV.	DATE	DESCRIPTION

This print contains confidential information which is the property of BEGA U.S. By acceptance this information, the borrower agrees that it will not be used for any other purpose other than that which is was loaned.