

**Tools Required:**

- 2mm hex key
- 11/32" Nut driver
- Phillips medium screwdriver

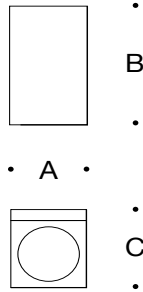

**Dimensions**

- A:** 3 "
- B:** 5 1/8 "
- C:** 3 7/8 "



**Protection Class:** IP64

**Weight:** 1.5 lb.

**Notice to Installer for 33 590:**

1. See page 2 for specific product safety warnings.
2. Mounts directly to a standard single-gang recessed wiring box (by others) using adaptor plate (supplied).
3. This product must be installed in accordance with the applicable installation code by a person familiar with the construction and operation of the product and the hazards involved.

**IMPORTANT: SILICONE RTV MUST BE APPLIED ON BOTH SIDES OF THE ADAPTOR PLATE TO ENSURE WATER TIGHT SEAL.**

**33 590 - Installation:**

1. Loosen (2) 2mm set screws under luminaire and remove outer casting with lens.
2. Feed luminaire wires through luminaire base and adaptor plate wireway hole.
3. Make supply wiring and luminaire wiring connections in the wiring box:
  - MAIN VOLTAGE SUPPLY WIRE TO BLACK LUMINAIRE WIRE
  - NEUTRAL (COMMON) SUPPLY WIRE TO WHITE LUMINAIRE WIRE
  - GREEN GROUND WIRE TO GREEN LUMINAIRE WIRE
- 0-10V Dimming (if applicable):
  - DIMMING CONTROL WIRE (+) TO POSITIVE DRIVER DIM CONTROL WIRE
  - DIMMING CONTROL WIRE (-) TO NEGATIVE DRIVER DIM CONTROL WIRE
4. Place a bead of silicone RTV around the outer edge of the back side of the adaptor plate that will come in contact with the finished wall (exterior applications only).
5. Attach luminaire base to adaptor plate over the mounting screws using the (2) nuts provided in the mounting kit. Tighten the nuts to back the screws into the wiring box and secure the plate to the box.

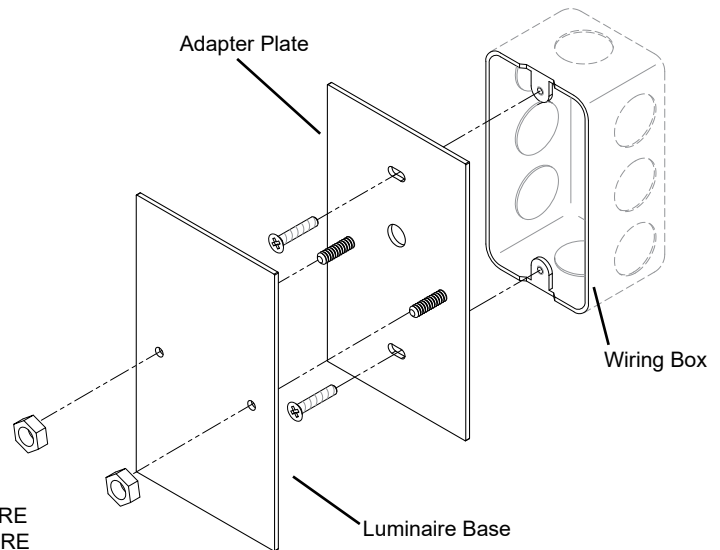

**IMPORTANT:** note position of orientation arrow on luminaire base and install accordingly.

6. Replace outer casting and tighten (2) set screws, making sure the gasket is seated properly.

**Relamping/Maintenance**

Loosen (2) 2mm set screws under luminaire and remove outer casting with lens. Clean luminaire and lens using only solvent-free cleansers. Replace lens and outer casing, making sure that the gasket is seated properly.

**Accessories**

Please refer to the appropriate accessory installation sheet for further instruction when applicable.

**Replacement Parts**

See label inside fixture for replacement LED part number. Consult factory for all other replacement components.

**Lamp:** 3.8W LED

In the interest of product improvement, BEGA reserves the right to make technical changes without notice.

## Product Safety Warnings:

**THIS PRODUCT MUST BE INSTALLED IN ACCORDANCE WITH THE APPLICABLE INSTALLATION CODE BY A PERSON FAMILIAR WITH THE CONSTRUCTION AND OPERATION OF THE PRODUCT AND THE HAZARDS INVOLVED. SUITABLE FOR WET LOCATIONS.**

**MIN 90°C SUPPLY CONDUCTORS.**

**CE PRODUIT DOIT ÊTRE INSTALLÉ SELON LE CODE D'INSTALLATION PERTINENT, PAR UNE PERSONNE QUI CONNAÎT BIEN LE PRODUIT ET SON FONCTIONNEMENT AINSI QUE LES RISQUES INHÉRENTS. CONVIENT AUX EMBLEMES MOUILLÉS.**

**LES FILS D'ALIMENTATION 90°C MIN.**